

LUBRICATION

ORDER

L05-4310-278-12

27 SEPTEMBER 1968

COMPRESSOR, ROTARY: AIR; FRAME MOUNTED, 2 WHEEL PNEUMATIC TIRED, GASOLINE ENGINE; 60 CFM, 6.5 PSI (HARRIS MODEL 4MV)

Reference: L05-2805-257-12 and C9100-IL

Intervals are based on normal hours of operations. Adjust to compensate for abnormal operations and severe conditions. During inactive periods, sufficient lubrication must be performed for adequate preservation.

Clean fittings before lubricating.

Relubricate after washing.

Clean parts with SOLVENT, dry cleaning, or with OIL, fuel, Diesel. Dry before lubricating.

Lubricate points indicated by dotted arrow shafts on both sides of equipment.

Drain gearcase when hot. Fill and check level.

FOLD

FOLD

LUBRICANT ● INTERVAL

INTERVAL ● LUBRICANT

Compressor Crankcase
Fill
2190
-TEP
100
(Remove relief fittings at each end of compressor, fill to proper level, clean and install fittings)

Wheel Bearings
GAA
1000

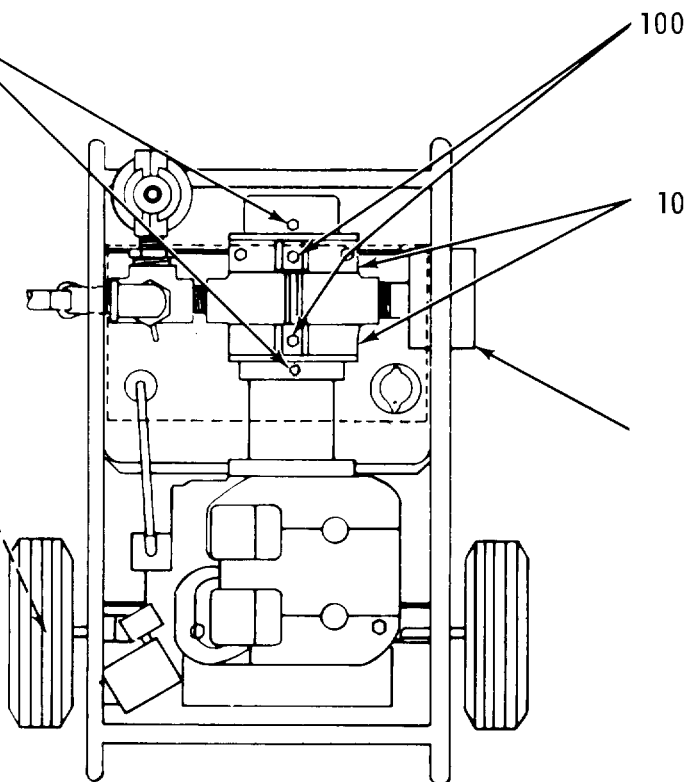

Compressor Drain Plug
(Drain and refill.)

Sight Level Gage
(Check level at each end of compressor.)

Air Cleaner
(Dry type, no lubrication required)

-KEY-

| LUBRICANTS | CAPACITY | EXPECTED TEMPERATURES | | | INTERVALS |
|---------------------------------------|-----------|-----------------------|------------------|---------------|---|
| | | Above + 32°F | + 40°F to - 10°F | 0°F to - 65°F | |
| 2190TEP-Lubricating Oil Steam Turbine | | 2190-TEP | 2110-TH | 2075-TH | Intervals given are in hours of normal operation. |
| Compressor Crankcase | 1/2 qt ea | | | | |
| GAA-Grease, Automotive and Artillery | | ALL TEMPERATURES | | | |

NOTES:

1. FOR OPERATION OF EQUIPMENT IN PROTRACTED COLD TEMPERATURES BELOW - 10°F. Remove lubricants prescribed in the key for temperatures above - 10°F. Relubricate with lubricants specified in the key for temperatures below - 10°F.

2. OIL CAN POINTS. Every 50 hours lubricate linkage, pins, springs, and all exposed adjusting threads with 2110TH.

3. LUBRICANTS. The following is a list of lubricants with the Military Symbols and applicable Specification numbers.

| | | |
|----------|-------------|-----------------|
| 2190-TEP | MIL-L-17331 | |
| 2110-TH | MIL-L-17672 | GAA MIL-G-10924 |
| 2075-TH | MIL-L-17672 | |

Copy of this Lubrication Order will remain with the equipment at all times; instructions contained herein are mandatory.

BY ORDER OF THE SECRETARY OF THE ARMY:

W. C. WESTMORELAND
General, United States Army,
Chief of Staff

OFFICIAL:

KENNETH G. WICKHAM,
Major General, United States Army,
The Adjutant General

FOLD

FOLD